

**SAE  
Standard  
Clevis Pin**

**Product  
Specification  
Sheet**

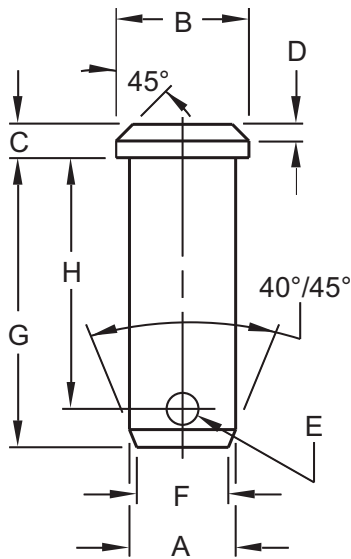

Part Number	BFCP 250	BFCP 312	BFCP 375	BFCP 500
A	.243 / .248	.306 / .311	.368 / .373	.491 / .496
B	0.375	0.438	0.500	0.625
C	0.094	0.094	0.125	0.156
D	0.031	0.031	0.031	0.047
E	.073 / .088	.104 / .119	.104 / .119	.136 / .151
F	.209 / .214	.259 / .265	.321 / .327	.431 / .439
G: Standard Tol. +0.020 - 0.000	49/64	15/16	1/16	1 23/64
H: Standard Tol. +0.020 - 0.000	43/64	13/16	15/16	1 13/64



Pins are standard only when conforming to dimensions shown above. Length is measured from under the head to end of the shank. Drilled holes are chamfered on both sides.

Material: ..... C1008 Low Carbon Steel  
 Finish: ..... Plain unless otherwise specified. Plating and/or hardening is available on request.



**Buckeye Fasteners Company**

5250 West 164th Street • Brook Park, Ohio 44142-1597

**(800) 437-1689 • Fax: (216) 267-3228**

buckeyefasteners.com • info@buckeyefasteners.com

© 2012 Buckeye Fasteners, Inc. All Rights Reserved

